

Type R622 And Type R652 Second-Stage Regulators

The Type R622 and R652 second-stage regulators are Underwriters Laboratories listed regulators designed for Two-Stage LP-Gas systems. These units are designed to reduce the outlet pressure from a first-stage regulator (usually 10 psig) to 11 inches water column. The R622 incorporates the standard straight-through flow design while the R652 is designed for back mount installations. Both have screened drip-lip vents are oriented over the inlet as standard.

Features

- **20 Year Recommended Replacement Life** - The R622 and R652 are designed using rugged time proven design concepts and constructed of corrosion resistant materials, both internally and externally. With proper installation and periodic inspection and maintenance the R622 and R652 designs will meet a 20 Year Recommended Replacement Life.
- **Improved Regulation** - Fisher's large fabric-reinforced diaphragm and spring assisted vent stabilizer deliver accurate and stable regulation.
- **Overpressure Protection** - The combination of a high capacity relief valve and large vent provide overpressure protection which exceeds UL standards by limiting the downstream pressure to 2 psig even in a double failure situation when used with a R622H.



Figure 1. Type R622 Second-Stage Regulator



Figure 2. Type R652 Second-Stage Regulator

- **Inlet Screen** - Fisher's stainless steel inlet screen reduces the amount of debris that can enter the regulator
- **Gauge Taps** – Built-in 1/8 inch NPT gauge taps orificed to a number 54 drill size on upstream and downstream for easy gas system checks.

Table 1. Ordering Information

Type Number	Capacity BTU/HR Propane ¹	Connections Inlet X Outlet	Outlet Adjustment Setting	Outlet Pressure Range
R622-BCF	875,000	1/2 inch x 1/2 inch FNPT	11" WC	9 – 13" WC
R622-CFF	1,400,000	1/2 inch x 3/4 inch FNPT		
R622-DFF		3/4 inch x 3/4 inch FNPT		
R652-DFF	1,000,000	3/4 inch x 3/4 inch FNPT	18" WC	13 – 20" WC
R622-CFGXA	1,125,000	1/2 inch x 3/4 inch FNPT		

1. Capacity is based on 10 PSIG inlet pressure and 2" WC droop.



Bulletin LP-7: R622 / R652

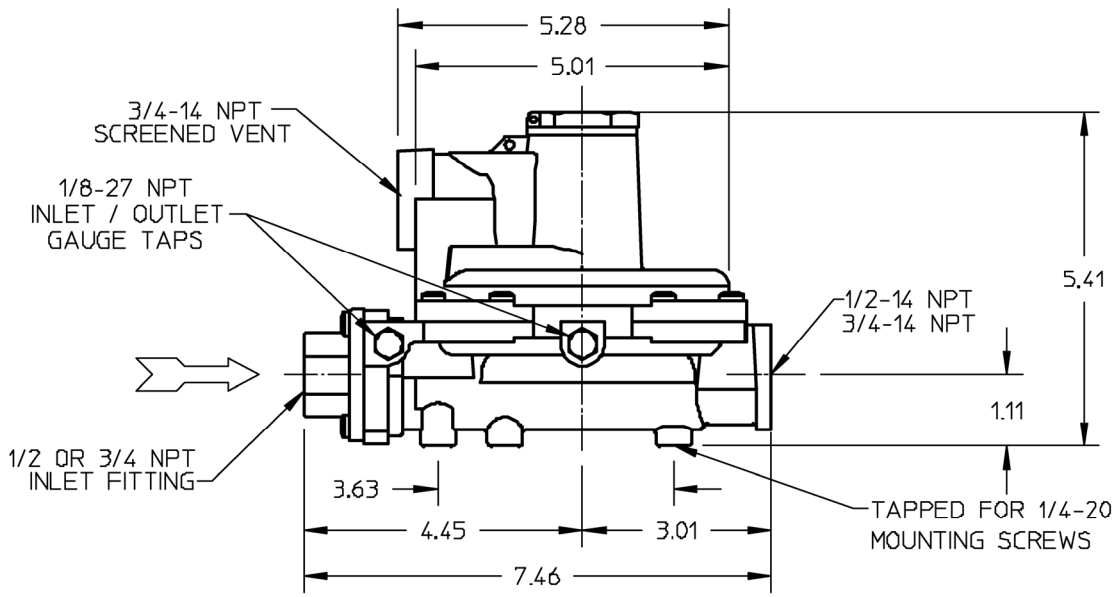

Figure 3. Type R622 Dimensions (inches)

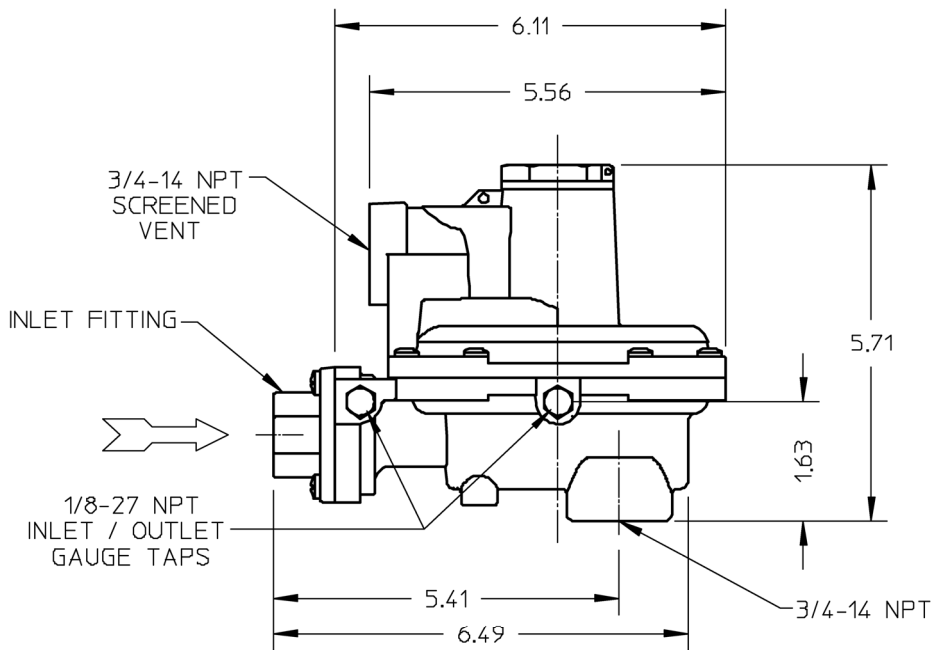

Figure 4. Type R652 Dimensions (inches)

For more information, visit our web site at www.FISHERregulators.com/LP or call 1-800-558-5853 for the Authorized Fisher LP-Gas Equipment Distributor near you.

The contents of this publication are presented for informational purposes only, and while every effort has been made to ensure their accuracy, they are not to be construed as warranties or guarantees, expressed or implied, regarding the products or services described herein or their use or applicability. We reserve the right to modify the designs or specifications of such products at any time without notice.

