

# Type 1051 and 1052 Diaphragm Rotary Actuators

The Type 1051 and 1052 spring-return diaphragm rotary actuators (figure 1) operate splined shaft rotary valves, such as eccentric disc (Type 8510B and 8560), Types 8532 and 9500, Design CV500 and V500 and Vee-Ball® (Design V150, V200 and V300) valves. Types 1051 and 1052 actuators are both suitable for on-off service or for throttling service. The primary difference between these actuators is that the Type 1052 actuator has a spring adjuster (see figure 2) which means it may be used with or without a positioner, depending on service requirements. The Type 1051 actuator, in throttling service, is normally equipped with a valve positioner. Refer to separate bulletins for valve and positioner information.

Both actuator types are designed for easy

installation of a broad range of options: limit switches, position indicating switches, positioners, and manual over-rides. Option applicability varies with actuator size. Refer to the specifications table and table 4 for information concerning option applicability and specifications.

### Note

**Neither Emerson, Emerson Process Management, nor any of their affiliated entities assumes responsibility for the selection, use and maintenance of any product. Responsibility for the selection, use, and maintenance of any product remains with the purchaser and end-user.**



SIZE 33

W8172-2



SIZE 60

W8508-2

Figure 1. Typical Type 1052 Actuators with Vee-Ball Valves and DVC6020 Positioners



# 1051 and 1052 Actuators

## Features

- **Application Flexibility**—Type 1051 and 1052 rotary actuators are available with fail-open or fail-close construction and can be mounted in any of four actuator-valve mounting positions. See figure 8 for mounting positions. These actuators can be mounted on a broad range of Fisher® valves (style F or G mounting), or used with other equipment (style H or J mounting).
- **Minimal Dead Band**—Single joint linkage with splined and clamped lever minimizes lost motion and improves control accuracy.
- **Long Service Life**—Rugged construction provides stability, corrosion resistance, and protection from deformation should over-pressurization occur.
- **Safety**—Actuator-valve linkage is completely enclosed, yet the valve packing adjustment remains accessible without removing any parts (see figures 3 and 4). For safety during disassembly, spring compression is controlled on the Type 1051 actuator. The Type 1052 actuator has an externally accessible spring adjuster to relieve spring compression (see figure 2).

## Options

**Top-Mounted Handwheel:** For infrequent use as a manual actuator or for use as an adjustable up travel stop (see figure 7). For repeated or daily manual operation, the unit should be equipped with a declutchable handwheel actuator.

**Declutchable Handwheel Actuator:** A side-mounted manual actuator can be used to provide on-site control and to provide override capabilities. Not available for size 20 actuators. See bulletin 61.8:1078 for handwheel actuator specifications.

**Limit Switches:** ■ Micro-Switch or NAMCO switches for one or two single-pole, double-throw contacts, or ■ GO® proximity switches for one or

two single-pole, double-throw contacts are available (see figure 6). Proximity switches are not available for Type 1052 size 70 actuators. See separate bulletins for limit switch information.

**Position Indicating Switch:** Type 304 switch for one through six single pole, double throw switch contacts are available. See separate bulletin for position indicating switch information.

**Positioner:** For precise positioning of the valve disc or ball, the actuator should be equipped with a positioner. Under some service conditions, the Type 1052 actuator may be used successfully in these applications without a positioner. For additional information, contact your Emerson Process Management™ sales office with complete service conditions.

**Adjustable Down-Travel Stop:** Used to limit the actuator stroke in the downward direction (see figures 5 and 6). Not available for size 20 and size 33 actuators.

**Adjustable Up-Travel Stop:** Used to limit the actuator stroke in the upward direction (see figures 5 and 6). Though these assemblies may be installed on the size 20 and 33 actuators, they are not necessary for standard operation because the size 20 and 33 actuators have integral travel stops.

**Actuator Locking Mechanism:** For size 33 actuators (figure 9) and size 40, 60, and 70 actuators (figure 10), an actuator locking mechanism is available. It can be used to keep the actuator in a locked position (the same as the spring-fail position) during maintenance. The padlock is customer supplied, and the mechanism requires a modified actuator housing.

**Pipe Away Vent:** Some applications use natural gas or other hazardous gases as a supply pressure to the actuator. These applications sometimes require the actuator housing to be vented, reducing the accumulation of gases. For new constructions and retrofit kit information, contact your Emerson Process Management sales office with complete service conditions.

**Specifications**

**Available Configurations**

- **Type 1051:** For on-off service or for throttling
- **Type 1052:** For on-off service without a positioner or for throttling services with or without a positioner
- Direct Acting:** Increasing loading pressure extends the diaphragm rod out of the spring barrel

**Actuator Sizes**

- Type 1051:** ■ 33, ■ 40, and ■ 60
- Type 1052:** ■ 20, ■ 33, ■ 40, ■ 60, and ■ 70

**Standard Diaphragm Pressure Ranges**

- Sizes 20 and 60:** ■ 0 to 1.2 bar (0 to 18 psig), ■ 0 to 2.3 bar (0 to 33 psig), and ■ 0 to 2.8 bar (0 to 40 psig)
- Sizes 33 and 40:** ■ 0 to 1.2 bar (0 to 18 psig), ■ 0 to 2.3 bar (0 to 33 psig), ■ 0 to 2.8 bar (0 to 40 psig), and ■ 0 to 3.8 bar (0 to 55 psig)
- Size 70:** ■ 0 to 2.3 bar (0 to 33 psig), ■ 0 to 2.8 bar (0 to 40 psig), and ■ 0 to 3.8 bar (0 to 55 psig)

**Maximum Diaphragm Sizing Pressure<sup>(1)</sup>**

- Size 20:** 3.4 bar (50 psig)
- Size 33:** 3.8 bar (55 psig)
- Size 40:** 4.5 bar (65 psig)
- Size 60:** 2.8 bar (40 psig)
- Size 70:** 3.8 bar (55 psig)

**Maximum Diaphragm Casing Pressure<sup>(5)</sup>**

- Size 20:** 4.1 bar (60 psig)
- Size 33:** 4.5 bar (65 psig)
- Size 40:** 5.2 bar (75 psig)
- Size 60:** 3.4 bar (50 psig)
- Size 70:** 4.5 bar (65 psig)

**Nominal Valve Shaft Rotation**

- 90 degrees (standard) or ■ 60 degrees (optional) for both actuators, or ■ 75 degrees (optional) for Type 1052 actuator only

**Valve Shaft Diameters, mm (Inches)**

- Size 20:** ■ 9.5 (3/8), or ■ 12.7 (1/2)
- Size 33:** ■ 12.7 (1/2), ■ 15.9 (5/8), or ■ 19.1 (3/4)
- Size 40:** ■ 12.7 (1/2), ■ 15.9 (5/8), ■ 19.1 (3/4), ■ 22.2 (7/8), ■ 25.4 (1), or ■ 31.8 (1-1/4)
- Size 60:** ■ 19.1 (3/4), ■ 22.2 (7/8), ■ 25.4 (1), or ■ 31.8 (1-1/4), ■ 38.1 (1-1/2), ■ 44.5 (1-3/4), or

- 50.8 (2)
- Size 70:** ■ 31.8 (1-1/4), ■ 38.1 (1-1/2), ■ 44.5 (1-3/4), or ■ 50.8 (2)

**Maximum Breakout Torque<sup>(2)</sup>**

- Type 1051:**
  - Size 33:* Up to 85 N•m (756 lbf•in)
  - Size 40:* Up to 322 N•m (2850 lbf•in)
  - Size 60:* Up to 626 N•m (5540 lbf•in)
- Type 1052:**
  - Size 20:* Up to 42 N•m (370 lbf•in)
  - Size 33:* Up to 132 N•m (1166 lbf•in)
  - Size 40:* Up to 371 N•m (3280 lbf•in)
  - Size 60:* Up to 730 N•m (6460 lbf•in)
  - Size 70:* Up to 1370 N•m (12,100 lbf•in)

**Stroking Time**

Dependent on actuator size, rotation, spring rate, initial spring compression, supply pressure, and size of supply piping. If stroking time is critical, consult your Emerson Process Management sales office

**Diaphragm Casing Displacement**

See table 1

**Construction Materials**

See table 3

**Material Temperature Capabilities<sup>(1)</sup>**

**Nitrile Diaphragm or O-Rings<sup>(3)</sup>:** -40 to 82°C (-40 to 180°F)

**Silicone Diaphragm:** -40 to 149°C (-40 to 300°F)

**Polyoxymethylene (POM) Push Rods and Guides:** -40 to 82°C (-40 to 180°F)<sup>(4)</sup> (POM rod and guides are used with lever operated switches for size 33 actuators only.)

**Travel Indication**

Graduated scale and pointer combination located on actuator end of valve drive shaft

**Pipe or Tubing Connections**

- Standard:** 1/4 NPT internal
- Optional:** ■ 1/2 or ■ 3/4 NPT internal, and ■ 3/4 NPT Pipe-Away vent opening

(continued)

## Specifications (continued)

### Mounting Positions

See figure 8

### Approximate Weights

See table 2

### Options

Option applicability varies with actuator size. Refer to table 4 and the Options section.

1. Use this value to determine the maximum torque output. The pressure/temperature limits in this bulletin and any applicable standard or code limitation for the actuator should not be exceeded.
2. Actual actuator torque available depends on specific construction and casing pressure. For information on torque requirements of the valve being considered, contact your Emerson Process Management sales office.
3. Nitrile O-rings are used in the optional top-mounted handwheel and in the optional up and down travel stop assemblies.
4. For higher temperature ratings, contact your Emerson Process Management sales office.
5. This maximum casing pressure is not to be used for normal operating pressure. Its purpose is to allow for typical regulator supply settings and/or relief valve tolerances.

Table 1. Diaphragm Casing Displacement

CASING SIZE	CLEARANCE VOLUME <sup>(1)</sup>		CASING VOLUME <sup>(2)</sup>			
			60 Degree Rotation		90 Degree Rotation	
	cm <sup>3</sup>	Inches <sup>3</sup>	cm <sup>3</sup>	Inches <sup>3</sup>	cm <sup>3</sup>	Inches <sup>3</sup>
20	655	40	1098	67	1245	76
33	623	38	1890	115	2390	146
40	1050	64	4100	250	5410	330
60	3540	216	11,600	708	15,200	927
70	3490	213	13,929	850	19,025	1161

1. Volume when the diaphragm is in the up position.  
2. Includes clearance volume.

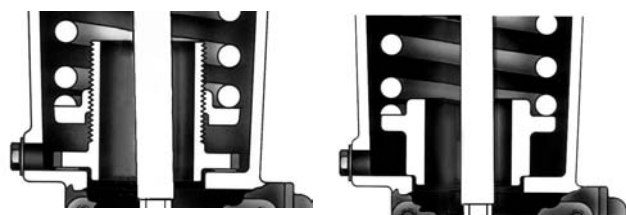
Table 2. Approximate Actuator Weights

SIZE	TYPE 1051 ACTUATOR		TYPE 1052 ACTUATOR		TOP-MOUNTED HANDWHEEL	
	Kg	Pounds	Kg	Pounds	Kg	Pounds
20	---	---	14	30	5.0	11
33	20	45	21	46	5.0	11
40	43	94	45	99	7.3	16
60	89	197	92	203	11	24
70	---	---	123	272	21.3	47

Table 3. Construction Materials

PART	ACTUATOR	MATERIAL
<b>Actuator</b>		
Actuator Housing and Spring Barrel <sup>(1)</sup>	All	Cast iron
Diaphragm	20	Nitrile on nylon
	33, 40, 60, and 70	Nitrile on nylon or silicone on polyester
Diaphragm Head	33, 40, and 60	Aluminum
	70	Cast Iron
Diaphragm Casing <sup>(1)</sup>	All	Pressed steel
Diaphragm Rod	All	Steel
Housing Cover	20	Steel
	33	Aluminum
	40, 60, and 70	Cast iron or aluminum
Lever	20	Steel
	33, 40, 60, and 70	Ductile iron
<b>Optional Top-Mounted Handwheel Assembly</b>		
Handwheel and Handwheel Body	All	Cast iron
Handwheel Stem	All	Bronze
O-Rings	All	Nitrile
Pusher Plate	20, 33, 40, and 60	Steel
	70	Cast iron or steel
<b>Optional Down Travel Stop Assembly</b>		
Closing Cap	40, 60 and 70	Brass
O-ring	40, 60 and 70	Nitrile
Stem	40, 60 and 70	Stainless steel
Travel Stop Body	40, 60 and 70	Cast iron
<b>Optional Up Travel Stop Assembly</b>		
Closing Cap	All	Brass
O-Ring	All	Nitrile
Stem	All	Bronze
Travel Stop Body	All	Cast iron

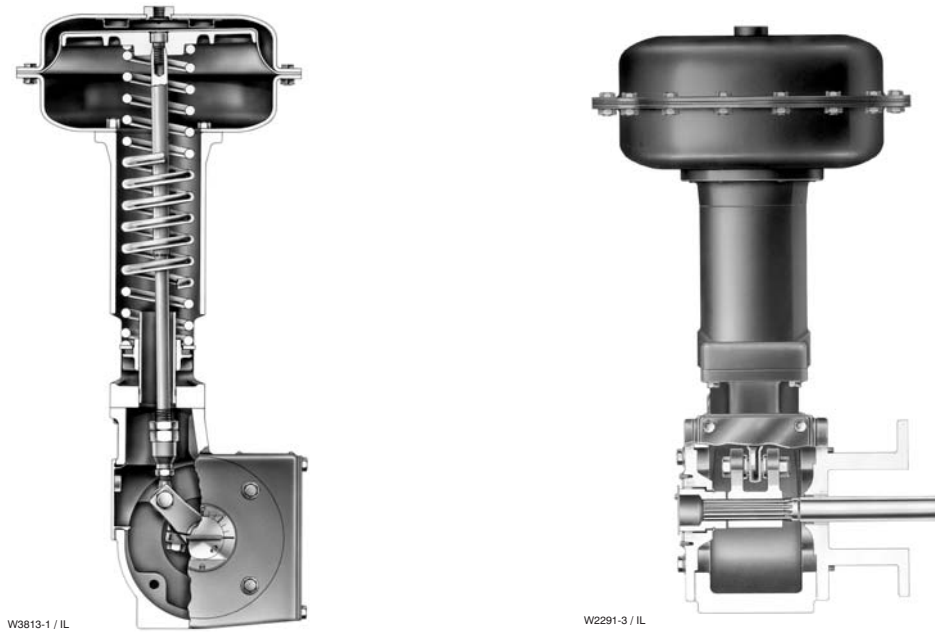
1. Housing, lower diaphragm casing, and spring barrel are an integral casing for sizes 20 and 33.



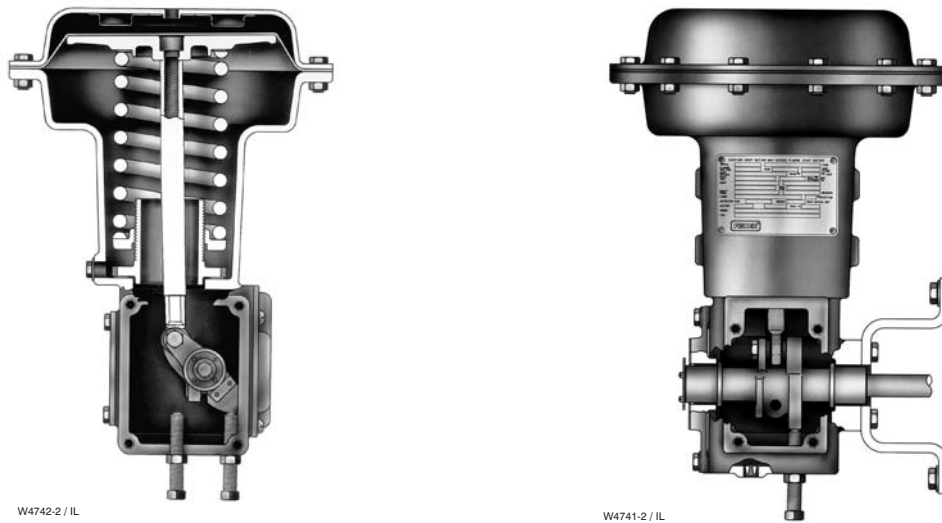
TYPICAL OF THE TYPE 1052 ACTUATOR WITH ADJUSTABLE SPRING SEAT

TYPICAL OF THE TYPE 1051 ACTUATOR WITH NON-ADJUSTABLE SPRING SEAT

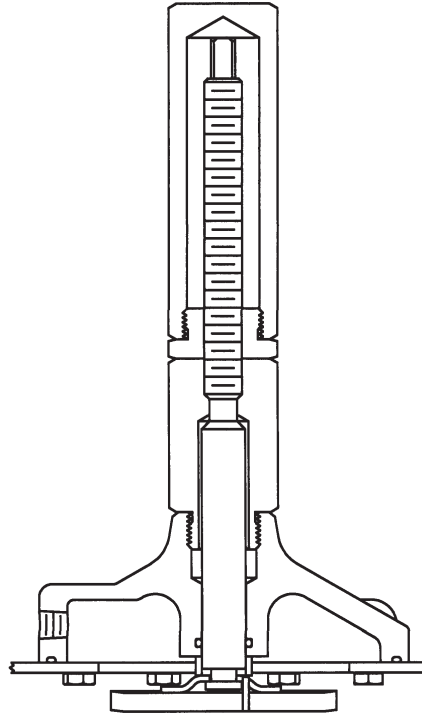
Figure 2. Sectional Views of Spring Seat Construction Details



*Figure 3. Sectional Views Typical of Size 40, 60, and 70 Actuators*

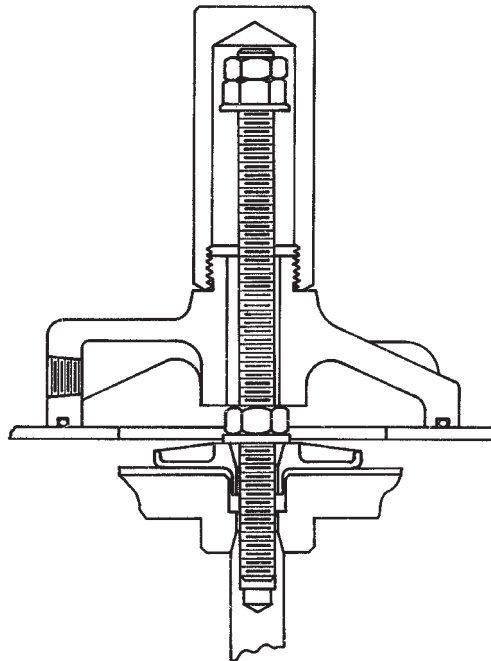


*Figure 4. Sectional Views of the Size 33 Actuator*



28A1761-B

**TYPICAL ADJUSTABLE UP TRAVEL STOP**



36A6250-B

**TYPICAL ADJUSTABLE DOWN TRAVEL STOP**

*Figure 5. Optional Adjustable Travel Stops*

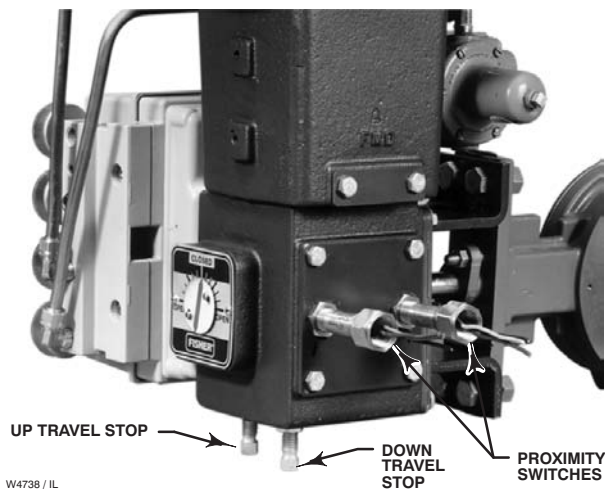
**Product Bulletin**

61.1:1051  
May 2007

**1051 and 1052 Actuators**

Table 4. Construction Features and Option Applicability by Actuator Size

ACTUATOR SIZE	ACTUATOR TYPE	STANDARD TRAVEL STOP		OPTIONAL TRAVEL STOP		OPTIONAL MANUAL OVERRIDE	ACCESSORY SWITCH MOUNTING		
		Style	Range of Adjustability	Style	Range of Adjustability		Proximity (GO) Switches	Mechanically Operated Switches	
20	1052	Internally adjustable up-travel stop and down-travel stop	30 degrees up-travel and 30 degrees down-travel	Top-mounted up-travel stop only	90 degrees	Top-mounted handwheel only	Externally mounted, lever operated	Externally mounted, lever operated	
33	1051	Externally adjustable up-travel stop and down-travel stop	35 degrees up-travel and 35 degrees down-travel			Top-mounted up-travel stop or down-travel stop	Top-mounted handwheel for infrequent operation or side-mounted manual actuator for routine operation		Integrally mounted, actuated by internal cams
	1052								Externally mounted, lever operated
40	1051	Fixed	Not applicable	Top-mounted up-travel stop or down-travel stop	Top-mounted handwheel for infrequent operation or side-mounted manual actuator for routine operation	Externally mounted, lever operated			
	1052					Not available			
60	1051	Fixed	Not applicable	Top-mounted up-travel stop or down-travel stop	Top-mounted handwheel for infrequent operation or side-mounted manual actuator for routine operation	Externally mounted, lever operated			
	1052					Not available			
70	1052	Fixed	Not applicable	Top-mounted up-travel stop or down-travel stop	Top-mounted handwheel for infrequent operation or side-mounted manual actuator for routine operation	Not available			



W4738 / IL

Figure 6. Size 33 Actuator with Externally Adjustable Travel Stops and Integrally Mounted, Cam Operated Proximity Switches



W3145 / IL

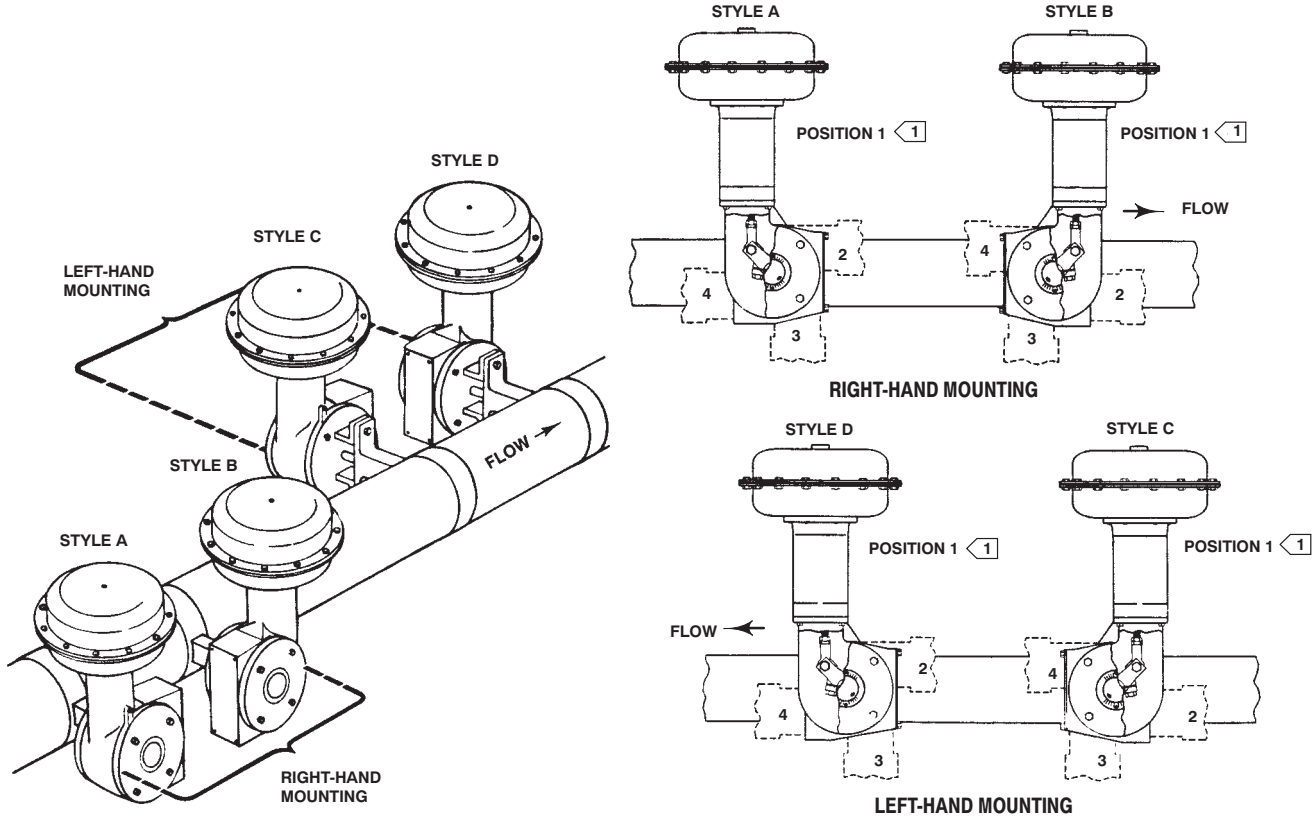
Figure 7. Top-Mounted Handwheel

# 1051 and 1052 Actuators

Table 5. Mounting Styles and Positions

MOUNTING	ACTION <sup>(1)</sup>	VALVE SERIES OR DESIGN				VALVE SERIES OR DESIGN			
		BALL/PLUG ROTATION TO CLOSE	V250	V150, V200 and V300	CV500 and V500	DISC/BALL ROTATION TO CLOSE	V250	8510B, 8532, 8560 and 9500	
Right-Hand	PDTC	CCW <sup>(3)</sup>	A	A	A	CW	NA	B	
	PDTO	CCW	B	B	B	CW	NA	A	
Left-Hand	PDTC	CCW	NA	D	D	CW	C	C	
	PDTO	CCW	NA	C	C	CW	D	D	
Left-Hand (Optional) <sup>(2)</sup>	PDTC	CW <sup>(4)</sup>	NA	C	NA	NA	NA	NA	
	PDTO	CW	NA	D	NA	NA	NA	NA	

1. PDTC—Push-down-to-close, and PDTO—Push-down-to-open.  
 2. A left hand ball will be required for NPS 3 through 12 V150, V200 and V300, Series B and NPS 14 through 20, with or without an attenuator.  
 3. CCW = counterclockwise  
 4. CW = clockwise



NOTES:  
 1 POSITION 1 IS STANDARD; POSITIONS 2 THROUGH 4 (SHOWN IN DOTTED LINES) ARE ALTERNATIVES.

43A6505-A  
 A1584-3

Figure 8. Mounting Styles and Positions (also see table 5)



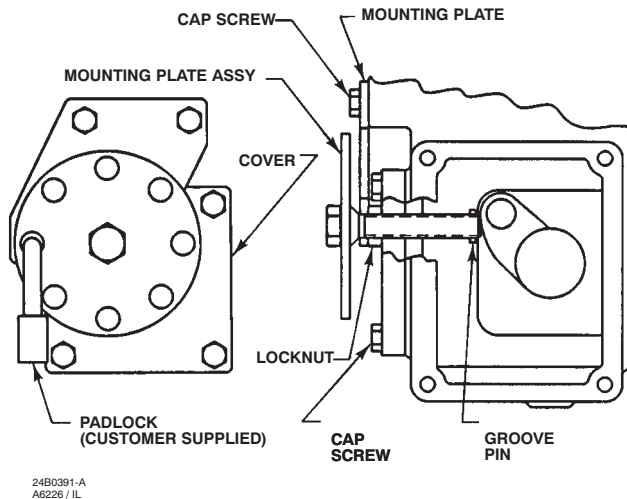


Figure 9. Actuator Locking Mechanism for Size 33

**Installation**

The actuator is normally positioned vertically in a horizontal pipeline. Four mounting styles and four positions for each style are possible (see figure 8). Due to its weight, the Type 1052 size 70 actuator must be externally supported if mounted in the horizontal position.

When looking in the direction of flow in the pipeline, an actuator is right-hand mounted when it is on the right side of the pipeline, and an actuator is left-hand mounted when it is mounted on the left side of the pipeline.

By Emerson Process Management definition, forward flow is into the face side of the disc or ball, and reverse flow is into the hub side of the disc or ball.

Dimensions for both actuator types are shown in figure 11. These dimensions should be used in conjunction with the mounting positions shown in figure 8. Make clearance considerations before mounting the actuator to determine the most suitable mounting position.

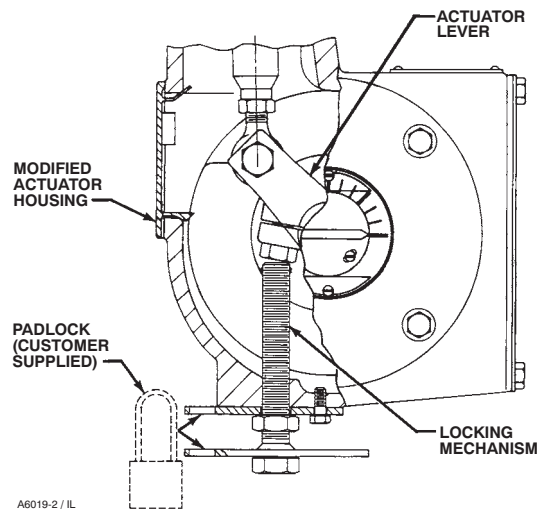


Figure 10. Actuator Locking Mechanism for Sizes 40, 60, and 70

**Adjustable Travel Stops**

Adjustable travel stops (in addition to those shown in figure 5) are available as discussed below.

As used here, down or downward means in a direction toward the valve shaft and away from the piston and diaphragm.

An adjustable down travel stop for Type 1051 (size 40 and 60) and Type 1052 (size 30, 40, 60, and 70) is installed in a special actuator housing. The assembly consists of a special housing, cap screw, locknut, lever, and rod end bearing. The cap screw can be positioned to limit downward travel of the actuator lever to any rotation between 0 and 90 degrees.

The locking mechanism shown in figures 9 and 10 is not to be used as a travel stop. Please specify an adjustable travel stop assembly instead.

# 1051 and 1052 Actuators

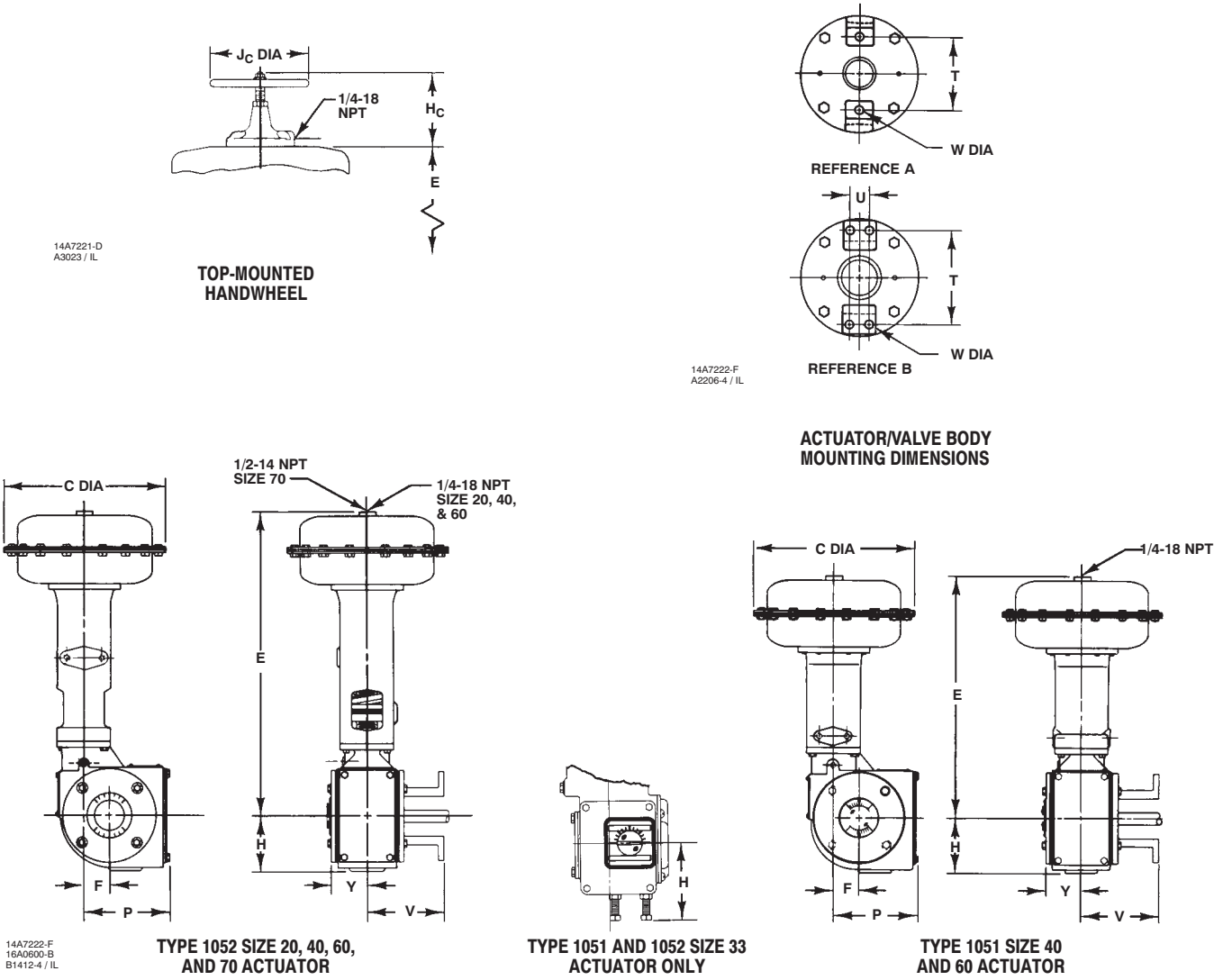


Figure 11. Dimensions (also see tables 6, 7 and 8)

# Product Bulletin

61.1:1051  
May 2007

# 1051 and 1052 Actuators

Table 6. Dimensions

ACTUATOR SIZE	C		E				F		H		P		Y	
	mm	Inches	Type 1051		Type 1052		mm	Inches	mm	Inches	mm	Inches	mm	Inches
			mm	Inches	mm	Inches								
20	251	9.88	---	---	256	10.06	18	0.69	76	3.00	52	2.06	59	2.32
33	289	11.38	338	13.31	338	13.31	33	1.31	116	4.56	92	3.62	65	2.56
40	505	13.12	505	19.88	607	23.88	54	2.12	114	4.50	175	6.88	73	2.88
60	473	18.62	749	29.50	876	34.50	64	2.50	121	4.75	186	7.31	76	3.00
70	536	21.12	---	---	849	33.44	64	2.50	121	4.75	186	7.31	76	3.00

Table 7. Actuator / Valve Body Mounting Dimensions

VALVE SHAFT DIAMETER		FIGURE REFERENCE	T		U		V		W	
mm	Inches		mm	Inches	mm	Inches	mm	Inches	mm	Inches
<b>Style F Mounting: Vee-Ball, 8532, 8510B and 8560 edisc Valves</b>										
12.7 - 15.9	1/2 - 5/8	A	117	4.62	---	---	137	5.38	14.2	0.56
19.1 - 25.4	3/4 - 1	B	152	6.00	32	1.25	160	6.31	14.2	0.56
31.8 - 38.1	1-1/4 - 1-1/2	B	235	9.25	46	1.81	148	5.81	17.5	0.69
44.5 - 50.8	1-3/4 - 2	B	273	10.75	51	2.00	286	11.25	20.6	0.81
<b>Style G Mounting: 9500 Series Valves</b>										
12.7	1/2	A	117	4.62	---	---	137	5.38	11.0	0.44
15.9 - 25.4	5/8 - 1	B	146	5.75	32	1.25	160	6.31	11.0	0.44
31.8 - 38.1	1-1/4 - 1-1/2	B	210	8.25	51	2.00	148	5.81	17.5	0.69
44.5 - 50.8	1-3/4 - 2	B	241	9.50	70	2.75	286	11.25	20.6	0.81

Table 8. Dimensions for Top-Mounted Handwheel

ACTUATOR SIZE	H <sub>C</sub>		J <sub>C</sub>	
	mm	Inches	mm	Inches
20	184	7.25	171	6.75
33	190	7.50	222	8.75
40	281	11.06	356	14.00
60	333	13.12	356	14.00
70	378	14.88	356	14.00

### Note

**Neither Emerson, Emerson Process Management, nor any of their affiliated entities assumes responsibility for the selection, use and maintenance of any product. Responsibility for the selection, use, and maintenance of any product remains with the purchaser and end-user.**

Vee-Ball and Fisher are marks owned by Fisher Controls International LLC, a member of the Emerson Process Management business division of Emerson Electric Co. Emerson Process Management, Emerson, and the Emerson logo are trademarks and service marks of Emerson Electric Co. GO is a mark owned by TopWorx, Inc. All other marks are the property of their respective owners.

*The contents of this publication are presented for informational purposes only, and while every effort has been made to ensure their accuracy, they are not to be construed as warranties or guarantees, express or implied, regarding the products or services described herein or their use or applicability. We reserve the right to modify or improve the designs or specifications of such products at any time without notice.*

Neither Emerson, Emerson Process Management, nor any of their affiliated entities assumes responsibility for the selection, use and maintenance of any product. Responsibility for the selection, use and maintenance of any product remains with the purchaser and end-user.

**Emerson Process Management**

Marshalltown, Iowa 50158 USA

Cernay 68700 France

Sao Paulo 05424 Brazil

Singapore 128461

[www.Fisher.com](http://www.Fisher.com)

