

M-5700TG Wall-Mounted Series

This unit produces hot water instantly from a steady supply of steam and cold water. All mixing units-hose stations in the M-5000TG/M-5700TG series are equipped with a dial-type gauge that indicates the wash water's exact temperature. Users can easily regulate the temperature by turning the unit's steam and cold water valves. As an added safety measure, these units shut off their steam source automatically if the cold water supply falls below 50 psi for any reason. This prevents hazardous steam from exiting the unit and causing steam burns.

Please review the chart below before purchasing an M-5000TG/M-5700TG unit.

REQUIRED STEAM MODEL NUMBER	REQUIRED STEAM PRESSURE*	REQUIRED WATER PRESSURE*	GPM
M-5700 L**	80-95 lbs.	50-80 lbs.	5-7
M-5700 M	96-130 lbs.	50-80 lbs.	4½-6
M-5700 H	131-150 lbs.	50-80 lbs.	4½-6

The M-5000 unit is available in bronze or chrome-plated material.

**Steam pressure required at installation site to ensure proper operation of mixing unit.*

*** Standard unit supplied.*



Shown: M-5700TG, stainless steel; shown with premium hose assembly and S-70 Series nozzle.

Available: M-5000TG, bronze

Specifications

- ♦ Maximum water temperature: 200°F/93°C
- ♦ Maximum working pressure: 150 psi steam

Please see reverse side for parts listing.



USA Headquarters

2801 Baglyos Circle ♦ Bethlehem, PA 18020

Phone: (484) 893-5080 ♦ Fax: (484) 893-5099 ♦ Toll Free: (877) STRAHMAN

www.strahmanvalves.com

France

Savoie Hexapole, F-73420 Mery, France

Tel: 33 (0) 4 79 35 78 00

Fax: 33 (0) 4 79 35 78 20

Germany

Zum Schwarzhof 14, 77704, Oberkirch, Germany

Tel: 49 (0) 7802 - 7037879

Fax: 49 (0) 7802 - 7037889

M-5700TG Wall-Mounted Series

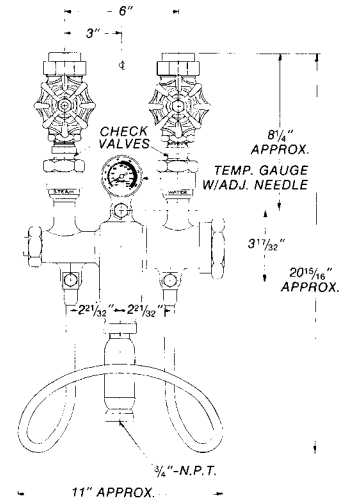
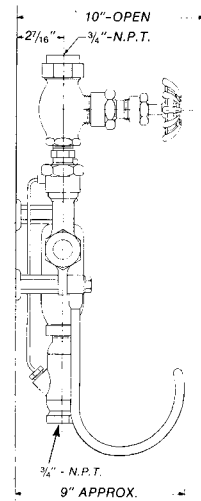
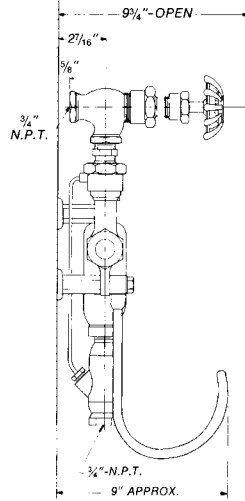
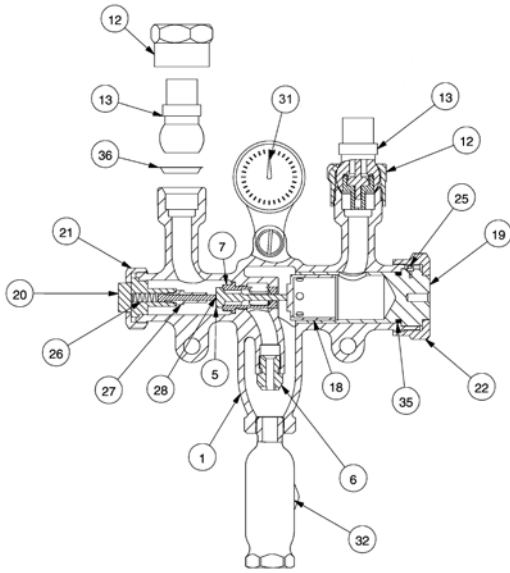

Note: Front view shown with Globe Valves.

PARTS

PART NO.	PART	M-5700 MATERIAL	PART NO.	PART	M-5700 MATERIAL
1	BODY (includes parts 6 and 7)	SST 316	19	WATER CHAMBER HOUSING (includes part 35)	SST 304
2	HOSE RACK CAP SCREW (not shown)	SST 304	20	POPPET GUIDE	SST 304
3	HOSE RACK LOCK WASHER (not shown)	SST 410	21	POPPET GUIDE NUT	SST 303
4	HOSE RACK CONNECTOR (not shown)	SST 303	22	BODY NUT	SST 303
5	STEAM POPPET (L, M, H)	SST 303	25	SET SCREW	SST 304
6	STEAM JET	SST 416	26	POPPET SPRING	SST 302
7	POPPET SEAT	SST 304	27	GUIDE EXTENSION	SST 416
8	HOSE RACK (not shown)	SST 302	28	PUSHER	SST 303
10	SPACER (not shown)	SST 416	31**	TEMP GAUGE	PLATED BRASS
11	WALL PLATE (not shown)	SST 304	35	"O" SEALING RING FOR WATER CHAMBER HOUSING	EPMD
12	BALL CHECK UNION NUT	SST 304	36	BALL CHECK GASKET	COPPER, TEFLON COATED
13†	BALL CHECK VALVES (includes part 36)	SST 303			
18	WATER CHAMBER	SST 303			

†Sold as a complete unit.

**Temperature gauge: 40-120°C/100-250°F.