



2PC DIRECT-MOUNT AUTOMATION SERIES

2PC DM85 Econoflo Series



Models:
#DM85-SS
#DM85-CS

Valve Features

- 2-Piece Body, Full Port Design
- 1/2" to 2" Sizes
- Threaded NPT Ends
- Body: WCB or CF8M, 316SS
- PTFE, RTFE or TFM Seats
- Pressure Rating:
1000 PSI
- Temperature Range:
-20° F - 450° F

Design Advantages

- ISO 5211 Direct Mounting Pad - Provides for precise shaft alignment & eliminates the need for brackets and couplings
- Improved Seat Material - Extends cycle life and reduces torque
- Blowout Proof Stem
- Locking Device standard for valves with handles
- Adjustable "Live Loaded" Stem Seal

Actuator Sizing Chart

Flo-Tite Actuator Selections are based on units with standard seats with clean fluid only at ambient temperature.

Maximum Temperature Limitations for Direct-Mount Actuators: Electric 150 °F; Pneumatic 180 °F.

Special Brackets are available for higher temperatures, consult factory.

All valves are sized for line pressure up to maximum 600 WOG. For higher line pressure applications, consult factory to assure proper actuator sizing.

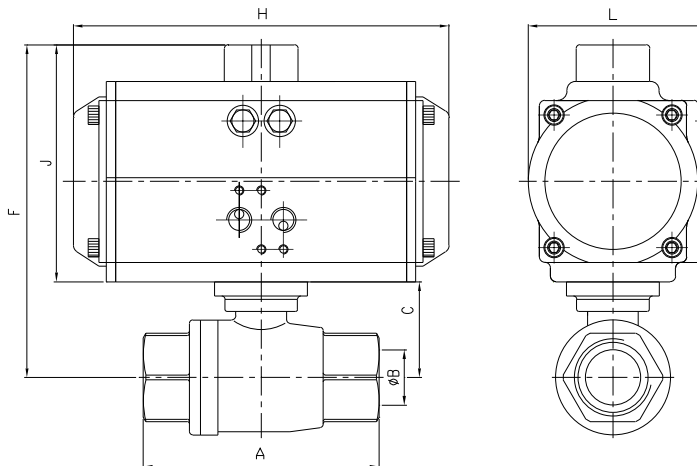

Size	SPRING RETURN 80 PSI								SPRING RETURN 60 PSI					DOUBLE ACTING 80 PSI					DOUBLE ACTING 60 PSI				
	A	B	C	Actuator	F	H	J	L	Actuator	F	H	J	L	Actuator	F	H	J	L	Actuator	F	H	J	L
1/2"	2.52	0.59	1.46	SR52	5.08	5.79	3.62	2.81	SR52	5.08	5.79	3.62	2.81	DA40	4.61	4.81	3.15	2.57	DA40	4.61	4.81	3.15	2.57
3/4"	2.72	0.79	1.59	SR52	5.21	5.79	3.62	2.81	SR52	5.21	5.79	3.62	2.81	DA52	5.21	5.79	3.62	2.81	DA52	5.21	5.79	3.62	2.81
1"	3.15	1.00	1.91	SR63	6.14	6.61	4.23	3.27	SR75	6.61	7.24	4.70	3.74	DA52	5.53	5.79	3.62	2.81	DA52	5.53	5.79	3.62	2.81
1 1/2"	4.13	1.50	2.69	SR75	7.39	7.24	4.70	3.74	SR83	7.76	8.03	5.07	4.05	DA63	6.92	6.61	4.23	3.27	DA75	7.39	7.24	4.70	3.74
2"	4.84	1.97	10.31	SR83	8.12	8.03	5.07	4.05	SR92	8.44	10.31	5.39	4.27	DA75	7.75	7.24	4.70	3.74	DA83	8.12	8.03	5.07	4.05

Flo-Tite's "DM" design eliminates mounting brackets and all their possible related problems. Ideally designed for low profile, cost effective industrial applications.

Design and Technical Data

Standards
ANSI/ASME - B16.11
ISO - 5211
MSS - SP25, SP72

Models
DM85-SS Stainless Steel
DM85-CS Carbon Steel

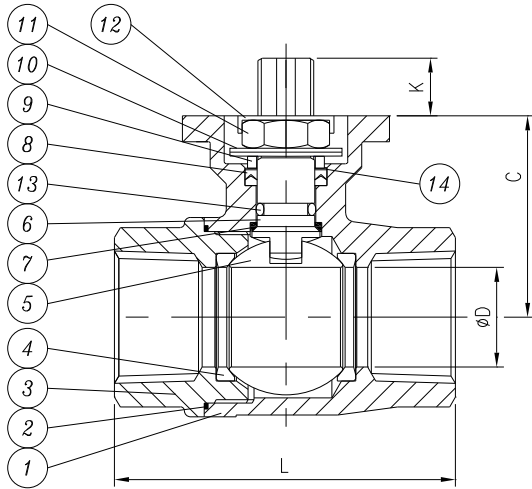
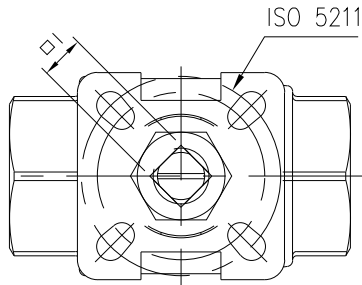

Materials of Construction

NO.	PARTS	DM85-SS
1	BODY	ASTM A351-CF8M
2	GASKET	PTFE
3	END CAP	ASTM A351-CF8M
4	SEAT	PTFE
5	BALL	ASTM A351-CF8M/316
6	STEM	ASTM A276-316
7	THRUST WASHER	PTFE
8	STEM PACKING	PTFE
9	GLAND	AISI 304
10	BELLEVILLE WASHER	AISI 301
11	PACKING NUT	AISI 304
12	NUT LOCK	AISI 304
13	O-RING	VITON
14	PACKING PROTECTOR	CARBON 25% PTFE

Steam Rating 150 PSI WSP
250 PSI available with Super-Tek II seats. Consult Factory

Vacuum Service to 20 microns

Dimensions and Weights

SIZE	C	ØD	L	I	K	Cv	Torque in-lb	Weight Lb	ISO 5211 Pattern
1/2"	1.46	0.59	2.52	0.35	0.33	15	60	0.71	F03-F04
3/4"	1.59	0.79	2.72	0.35	0.35	35	70	0.93	F03-F04
1"	1.91	1.00	3.15	0.43	0.55	68	95	1.60	F04-F05
1 1/4"	2.05	1.26	3.62	0.43	0.55	110	150	c/f	F04-F05
1 1/2"	2.69	1.50	4.13	0.55	0.71	155	200	3.86	F05-F07
2"	3.05	1.97	4.84	0.55	0.71	300	320	5.97	F05-F07



Leak Detection Window Prevents actuator damage in the unlikely event of stem leakage

Stem Seal Design

Flo-Tite's triple stem seal detail provides for an extended valve cycle life. The primary seal is a seal ring that fits firmly on a taper portion of the stem shoulder. The secondary (back-up) seal is provided by an O-ring and a set of Vee packing rings, energized by belleville washers. This design adjusts packing compression to compensate for wear, pressure or temperature fluctuations.

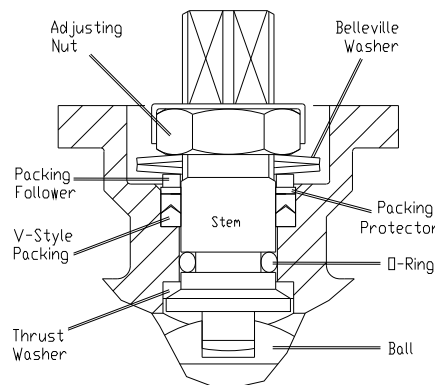

Pressure/Temperature Chart

