



D-LINE® two-piece Floating Ball Valve has been designed to handle extreme service applications with unsurpassed reliability. Valve body machined from solid wrought material providing maximum strength and virtually no porosity. It integrates the proven sealing technology and the design capability to tackle the most demanding application. We have dedicated ourselves to providing the highest quality valve products to satisfy our customers expectations. Floating ball valves are manufactured in strict accordance with all applicable ANSI, ASME and standards.

APPLICATIONS

D-LINE® Ball Valves serve multi-national end users in a wide range of applications in many industries including:

- Chemical & Petrochemical
- Ship building industries
- Fiber industries
- Food industries
- Oil refinery industries
- Desalination industries
- Steel & iron industries

DESIGN FEATURES

- Floating ball design
- Blow-out proof stem design
- Face to face to per ASME B16.10
- Flange dimensions to per ASME B16.5
- Split body to per ASME BS5351
- Locking handle operator or gear operator
- Sour services to per NACE MR-0175
- Antistatic grounding device
- Face to face to per ASME B16.10
- Bidirectional design
- Mounting ISO 5211

TEST SPECIFICATION			
TEST ACCORDANCE TO PER API 598			
CLASS	150	300	600
NOMINAL PRESSURE	285PSI	740PSI	1440PSI
SHELL TEST (WATER)	450PSI	1125PSI	2225PSI
SEAT TEST (WATER)	315PSI	815PSI	1630PSI
AIR TEST	80PSI	80PSI	80PSI

FEATURES	
SIZE	1" - 10"
CLASS	150/300/600
PORT	FULL
CONNECTION	FLANGED RF

MARKING BODY		
5132FF SERIES	5332FF SERIES	5632FF SERIES
2" - 150	2" - 300	2" - 600
CF8M	CF8M	CF8M
HEAT #	HEAT #	HEAT #

MARKING BONNET
CF8M
HEAT #

PRESSURE - TEMPERATURE RATING

These ratings are conservative guide for general service.

Previous experience in process or new development may permit applications above those shown.

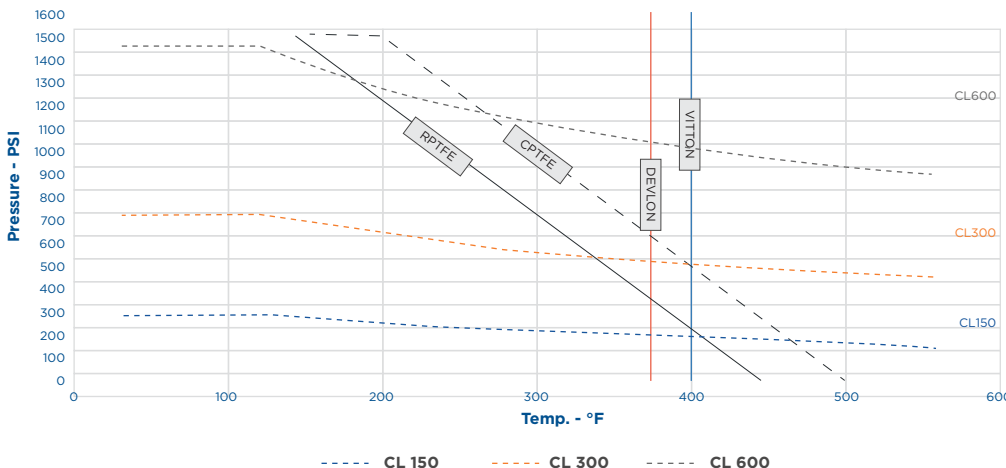

The graph lines represent the maximum pressure/temperature rating of the seat material. When selecting a seat material, the lower rating between the valve body and seat should be considered. For more information please consult factory.

Stainless Steel CF8M
ASME B16.34 Ratings
Material Limits

DIMENSIONS

BILL OF MATERIAL LIST		
No.	DESCRIPTION	MATERIAL
1	SCREW	ASTM A-193 Gr. B8
2	WASHER	ASTM A-240
3	HANDLE	ASTM A-216 Gr. WCB
4	RETAINING RING	AISI SAE-1065
5	ORIENTATION PATCH	ASTM A-240
6	SCREW	ASTM A-193 Gr. B8
7	GLAND	ASTM A-351 Gr. CF8M
8	PACKING	PTFE
9	STEM GASKET	PTFE
10	STEM	ASTM A-182 Gr. 316
11	GASKET	PTFE
12	BONNET	ASTM A-351 Gr. CF8M
13	NUT	ASTM A-194 Gr. 8
14	STUD	ASTM A-193 Gr. B8
15	BALL	ASTM A-182 Gr. 316
16	BODY	ASTM A-351 Gr. CF8M
17	SEAT	PTFE

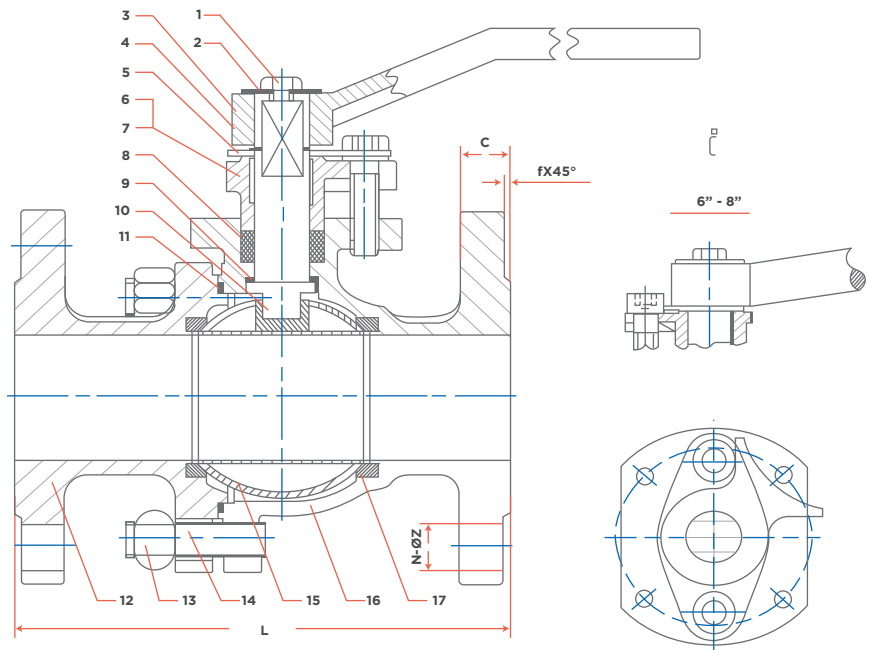

DIMENSIONS & WEIGHTS											
FIGURE	SIZE		ØD	ØK	Ød	ØD1	f	C	N-ØZ	L	WEIGHT (KG)
5132FF-06	1"	DN 25	4.33	3.13	2.00	0.98	0.08	0.46	4 - 0.63	5.00	3.70
5132FF-08	1 1/2"	DN 40	4.92	3.87	2.87	1.50	0.08	0.58	4 - 0.63	6.50	5.50
5132FF-09	2"	DN 50	5.91	4.75	3.63	1.97	0.08	0.64	4 - 0.75	7.01	8.00
5132FF-10	2 1/2"	DN 65	7.09	5.50	4.13	2.56	0.08	0.70	4 - 0.75	7.48	12.00
5132FF-11	3"	DN 80	7.48	6.00	5.00	3.15	0.08	0.77	4 - 0.75	7.99	15.00
5132FF-12	4"	DN 100	9.06	7.50	6.19	3.94	0.08	0.96	8 - 0.75	9.02	23.00
5132FF-14	6"	DN 150	11.02	9.50	8.50	5.91	0.08	1.02	8 - 0.87	15.51	48.00
5132FF-15	8"	DN 200	13.58	11.75	10.63	7.87	0.08	1.14	8 - 0.87	17.99	80.00

Dimensions are expressed in inches