

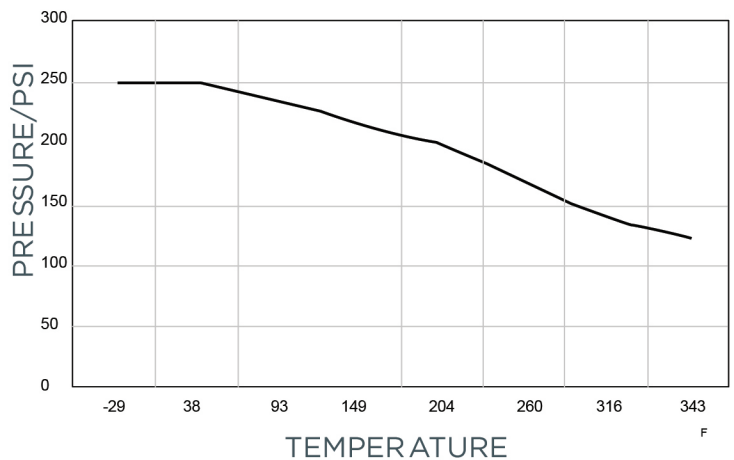

- Butterfly Valves are ideal for heavy duty applications such as fire protection, water treatment, food & beverage, pharmaceutical, mining, and many others.
- Every valve is factory-tested to 110% of its pressure rating for optimum performance in the field.
- The unique resilient seat is designed to seal against the disc, isolating the valve body and stem from the line.
- Face to Face ISO 5752
- Mounting Pad ISO 5211
- Flange ANSI 150

ITEM	Part name	Materials
1	BODY	Ductil Cast Iron: ASTM A53665-45-12.
2	UPPER STEM	StainlessSteel ASTM A276 Type: 316
3	SEAT	NBR (BUNA)
4	SPRING PIN	CARBOON STEEL
5	LOWER STEM	StainlessSteel: ASTM A276 Type: 316
6	DISC	Ductile Cast Iron (Nickel plated) ASTM A536 65-45-12 Stainless Steel: ASTM A351, CF8M
7	O-RING	NBR (BUNA)
8	BUSHING	PTFE
9	GREACE FITTING	BRONZE

Pressure-temperature curve



FLOW COEFFICIENTS

Cv Values (US-GPM @ 1/P)

SIZE	10°	20°	30°	40°	50°	60°	70°	80°	90°
2"	0.06	3	7	15	27	44	70	105	115
2 1/2"	0.1	6	12	25	45	75	119	178	196
3"	0.3	9	18	39	70	116	183	275	302
4"	0.3	17	36	78	139	230	364	546	600
5"	0.5	29	61	133	237	392	620	930	1022
6"	0.8	45	95	205	366	605	958	1437	1579
8"	2	89	188	408	727	1202	1903	2854	3136
10"	3	151	320	694	1237	2049	3240	4859	5340
12"	4	234	495	1072	1911	3162	5005	7507	8250

200 PSI TORQUE*

SIZE	Torque (N.m)
2"	19
2-1/2"	30
3"	39
4"	62
5"	95
6"	138
8"	226
10"	360
12"	514

*DIMENSIONS ARE EXPRESSED IN INCHES

DIMENSIONS LIST

SIZE	A	B	C	E	H	J	K	L	S	T	W	WEIGHT (KG)
2"	3	3.93	1.03	4.12	4	3.25	.437	1.65	.625	1.25	.375	2.80
2-1/2"	3.34	4.59	1.03	4.87	4	3.25	.437	1.75	.625	1.85	.375	3.20
3"	3.65	4.90	1.03	5.37	4	3.25	.437	1.78	.625	2.56	.375	3.60
4"	4.28	6	1.28	5.37	4	3.25	.437	2.04	.625	3.54	.437	5.20
5"	4.84	6.12	1.28	7.75	4	3.25	.437	2.12	.625	4.37	.50	6.40
6"	5.34	6.68	1.28	8.75	4	3.25	.437	2.18	.625	5.70	.50	7.50
8"	6.53	9.43	1.28	11	6	5	.562	2.37	.875	7.59	.625	14.00
10"	7.84	11.71	1.28	13.37	6	5	.562	2.57	.875	9.48	.625	19.20
12"	9.37	11.81	1.28	16.12	6	5	.562	3.03	1.12	11.50	.75	32.00

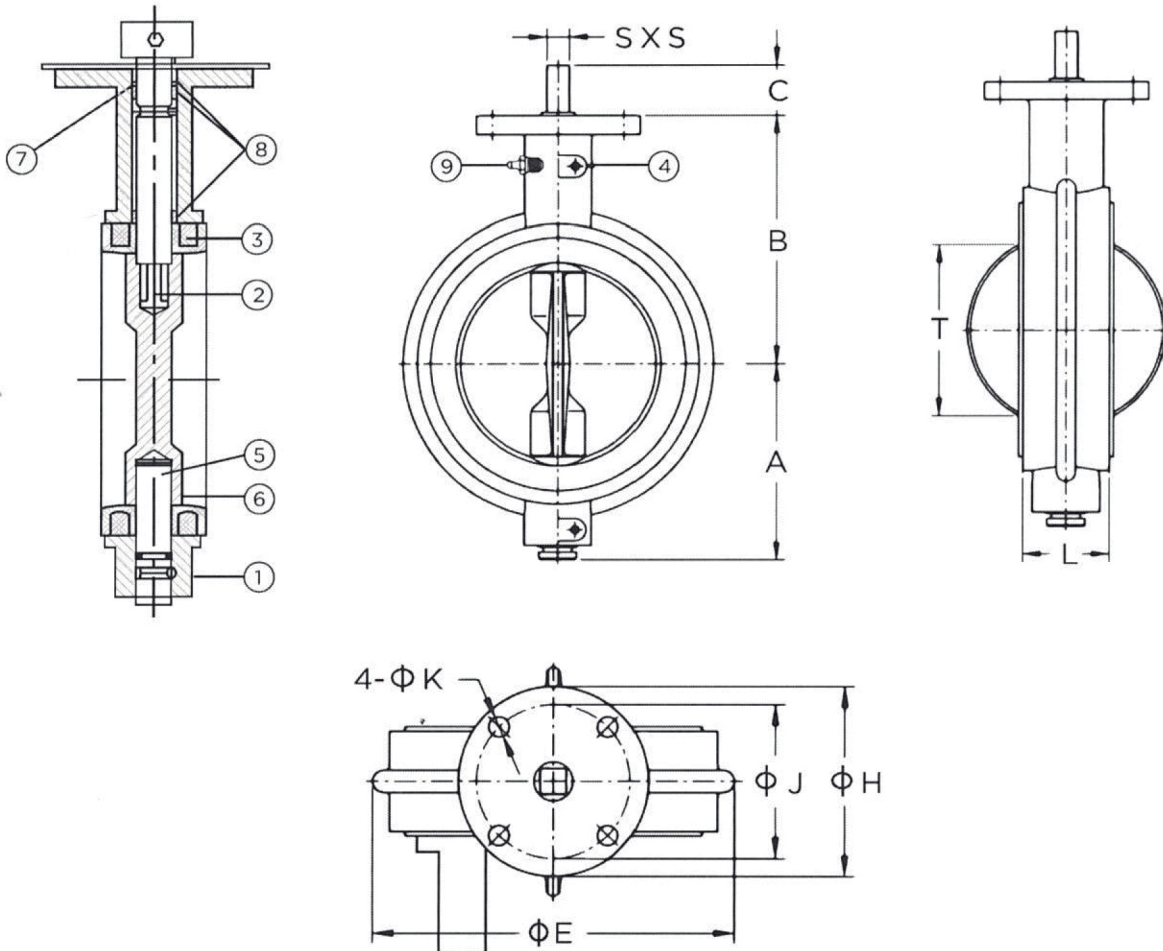



- 1"-1/2" & 14" through 36" butterfly valve specifications
- Butterfly Valves are ideal for heavy duty applications such as fire protection, water treatment, food & beverage, pharmaceutical, mining, and many others.
- Every valve is factory-tested to 110% of its pressure rating for optimum performance in the field.
- The unique resilient seat is designed to seal against the disc, isolating the valve body and stem from the line.
- Face to Face ISO 5752
- Mounting Pad ISO 5211
- Flange ANSI 150

ITEM	Part name	Materials
1	BODY	Ductil Cast Iron: ASTM A536 65-45-12.
2	STEM	Stainless Steel: ASTM A276 Type 410
3	TAPPER PIN	Stainless Steel: ASTM A276 Type 304
4	SEAT	NBR (BUNA), -4 ~ 212°F
5	DISC	Ductile Cast Iron (Nickel Plated): ASTM A536 Gr. 65-45-12 Stainless Steel: ASTM A351 Gr. CF8M
6	O-RING	NBR (BUNA)
7	BUSHING	PTFE
8	KEY	Carbon Steel

Pressure-temperature curve

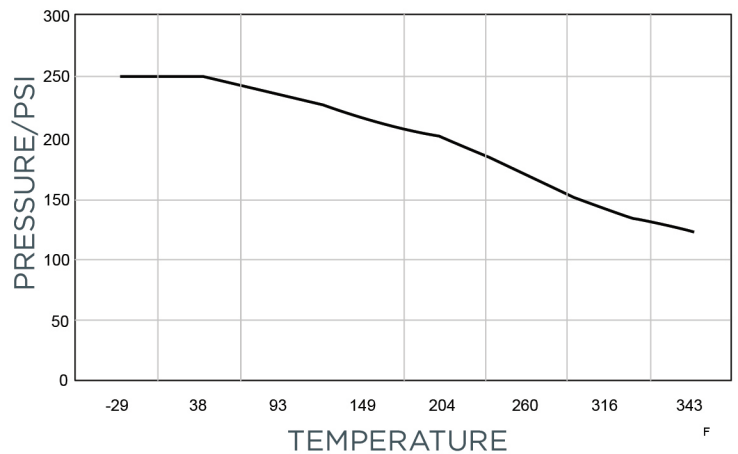

FLOW COEFFICIENTS

Cv Values (US-GPM @ 1/P)

SIZE	10°	20°	30°	40°	50°	60°	70°	80°	90°
1"	0.02	1.01	2.16	4.70	8.10	14.30	23.00	37.00	41.00
1 1/2"	0.04	1.92	4.10	8.70	15.00	26.00	41.00	65.00	72.00
14"	6.00	338.00	715.00	1549.00	2761.00	4568.00	7230.00	10844.00	11917.00
16"	8.00	464.00	938.00	2130.00	3797.00	6282.00	9942.00	14913.00	16388.00
18"	11.00	615.00	1302.00	2822.00	5028.00	8320.00	13168.00	19752.00	21705.00
20"	14.00	791.00	1648.00	3628.00	6465.00	10698.00	16931.00	25936.00	27908.00
24"	22.00	1222.00	2587.00	5605.00	9989.00	16528.00	26157.00	39236.00	43116.00
30"	37.00	2080.00	4406.00	9546.00	17010.00	28147.00	44545.00	66818.00	73246.00
36"	260.00	3050.00	6730.00	12740.00	20220.00	32500.00	52500.00	79600.00	87500.00

200 PSI TORQUE*

SIZE	Torque (N.m)
1"	N/A
1-1/2"	12.50
14"	627.10
16"	947.00
18"	1452.50
20"	1717.70
24"	2962.40
30"	5303.80
36"	9774.40

*All torque values shown on chart are for "wet (water and other non-lubricating media) on-off service. Under certain conditions, hydrodynamic torque can meet or exceed seating and unseating torques. When designing valve systems, hydrodynamic torque must be considered to help ensure selection or application.

DIMENSIONS LIST

SIZE	A	B	C	D	E	M	H	J	I-ØK	L	T	W	WEIGHT (KG)
1"	2.40	4.33	1.26	0.40	3.13	0.63	2.56	1.97	4-.28	1.18	1.06	0.39	2.20
1-1/2"	2.76	5.71	1.26	0.50	3.87	0.63	2.56	1.97	4-.28	1.30	1.06	0.39	2.45
14"	10.91	14.49	1.77	1.25	18.75	1.15	4.92	4.02	4-.45	3.03	12.80	0.94	46.00
16"	12.13	15.75	2.00	1.31	21.25	1.14	8.27	6.50	4-.87	3.39	14.96	1.06	75.00
18"	13.46	16.61	2.00	1.50	22.75	1.26	8.27	6.50	4-.87	4.13	16.85	1.06	89.00
20"	14.72	18.86	2.52	1.63	25.00	1.26	8.27	6.50	4-.87	5.12	18.66	1.26	128.00
24"	18.07	22.13	2.76	2.00	29.50	1.37	8.27	6.50	4-.87	5.98	22.64	1.42	206.00
30"	21.46	25.59	2.84	2.17	36.00	1.25	11.81	10.00	8-.71	6.50	28.58	2.50	375.00
36"	25.00	30.24	3.03	2.95	42.75	1.50	11.81	10.00	8-.71	8.15	33.03	2.95	563.00

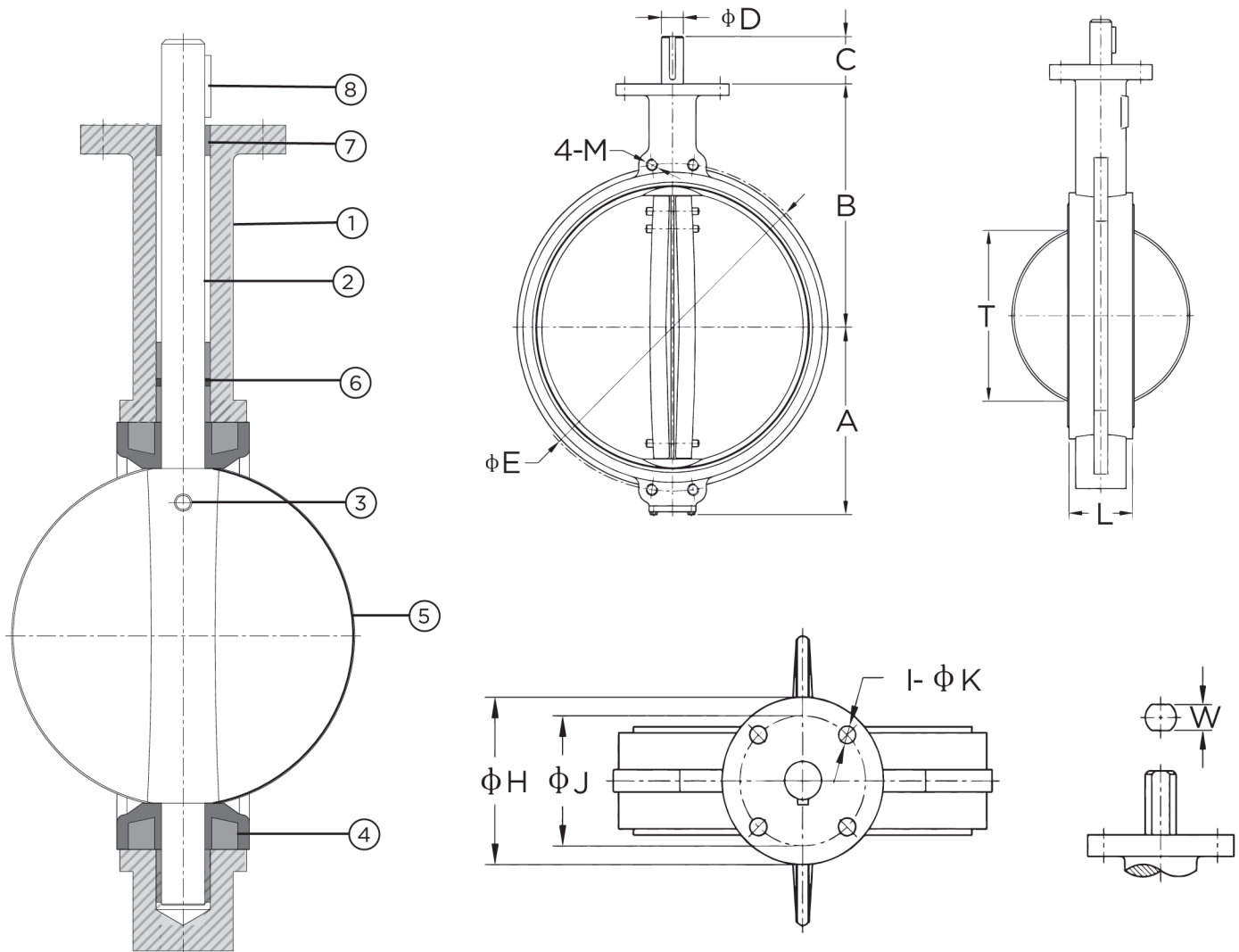

*DIMENSIONS ARE EXPRESSED IN INCHES