

## CHECK VALVE ANSI CLASS 800 THREADED END, FORGED STEEL



### TECHNICAL SPECIFICATION

SHELL WALL THICKNESS: API 602  
 VALVE DESIGN: API 602  
 THREAD: ASME B1.20.1  
 SOUR SERVICE: NACE MR-0175  
 UNIVERSAL TRIM 8

### TEST SPECIFICATION

TEST ACCORDANCE TO PER API 598  
 NOMINAL PRESSURE: 1980 PSIG  
 SHELL TEST: 2970 PSIG  
 SEAT TEST: 1628 PSIG  
 AIR TEST: 87 PSIG

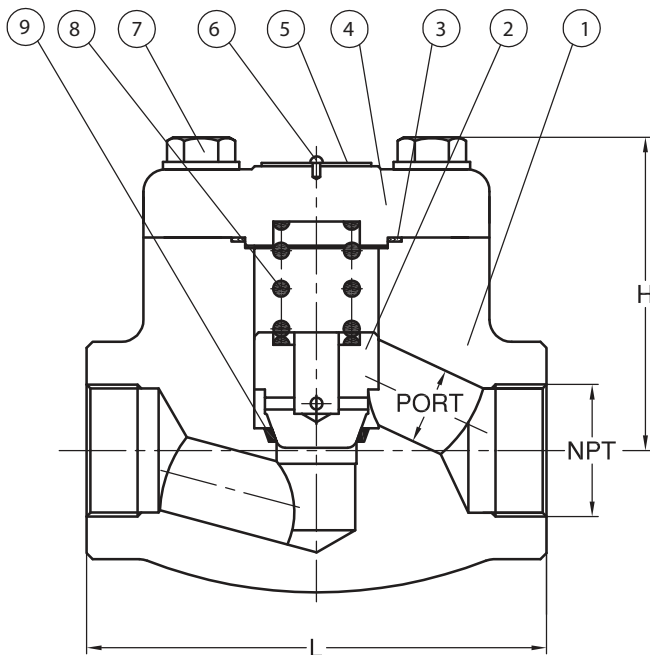

### MATERIAL LIST

1	BODY	ASTM A-105N
2	DISC	ASTM A-276 Gr. 420
3	BODY SEAL	SS304+GRAPHITE
4	COVER	ASTM A-105N
5	NAMEPLATE	ALUMINIUM
6	RIVET	SS304
7	BODY BOLT	ASTM A-193 Gr. B7
8	SPRING	SS304
9	SEAT	ASTM A-105+STL#6

### DIMENSIONS & WEIGHT'S

FIGURE	SIZE	PORT	L	H	G	NPT	WEIGHT (KG)	CRACKING PRESSURE (PSI)
2828T-02	1/4"	DN8	0.24	3.11	2.32	0.37	1.32	7.25
2828T-03	3/8"	DN10	0.24	3.11	2.32	0.41	1.32	7.25
2828T-04	1/2"	DN15	0.39	3.11	2.32	0.54	1.32	7.25
2828T-05	3/4"	DN20	0.53	3.62	2.32	0.55	1.45	7.25
2828T-06	1"	DN25	0.69	4.37	2.83	0.69	2.54	7.25
2828T-07	1 1/4"	DN32	0.89	4.65	3.23	0.71	3.27	7.25
2828T-08	1 1/2"	DN40	1.13	5.51	3.39	0.72	3.95	7.25
2828T-09	2"	DN50	1.44	6.77	4.06	0.76	6.77	8.70

\* WEIGHT IS ESTIMATED  
 \*DIMENSIONS ARE EXPRESSED IN INCHES