

1000 PSI 1 PC RP BALL VALVE

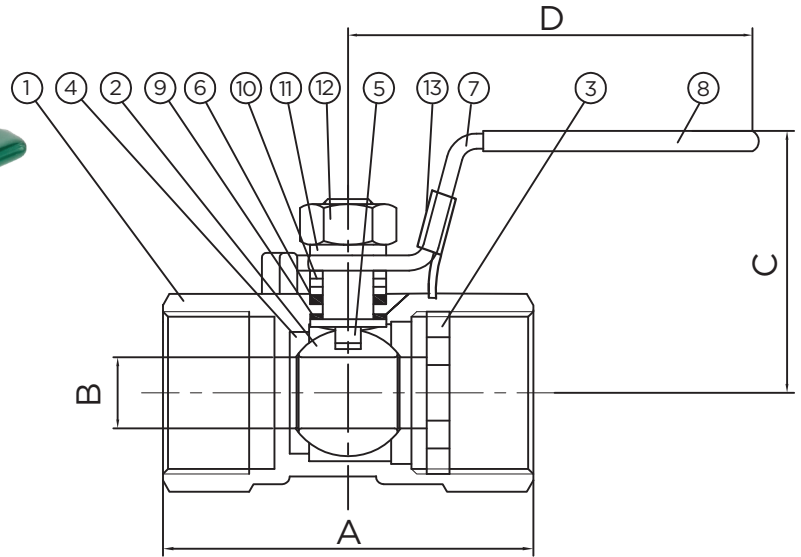
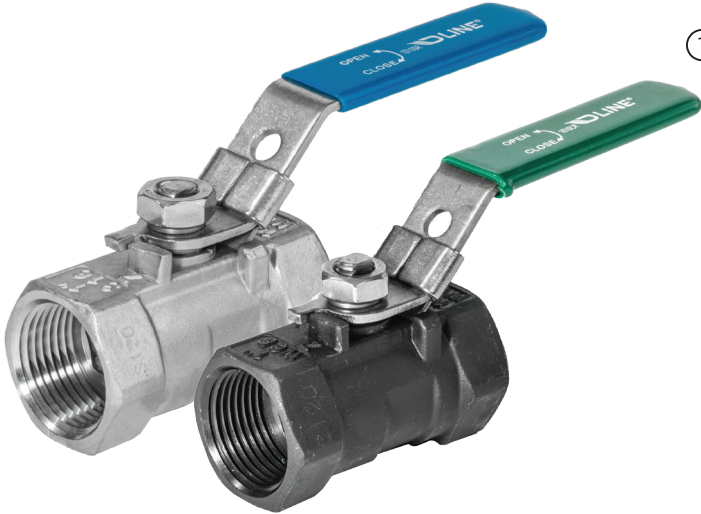

FEATURES

SIZE:	1/4" - 2"
PORT:	REDUCED
PRESSURE:	1000 WOG
TEMPERATURE:	-50 TO 450F°
CONNECTION:	FEMALE NPT

TECHNICAL SPECIFICATION

NPT THREADS AS PER ASME B1.20.1
 BLOW-OUT-PROOF STEM DESIGN
 LOCKING HANDLE
 IN COMPLIANCE WITH NACE MR-0175
 SUITABLE FOR WATER, OIL & GAS

MATERIAL LIST

		1010SR	1010CR
1	BODY	SS316	A216 Gr. WCB
2	BALL	SS316	SS304
3	CAP	SS316	A216 Gr. WCB
4	SEAT	VIRGIN PTFE	VIRGIN PTFE
5	STEM	SS316	SS304
6	STEM PACKING	VIRGIN PTFE	VIRGIN PTFE
7	HANDLE	SS201	SSS201
8	HANDLE COVER	PVC	PVC
9	THRUST WASHER	VIRGIN PTFE	VIRGIN PTFE
10	GLAND BUSHING	SS304	SS304
11	HANDLE WASHER	SS304	SS304
12	NUT	A2-70	A2-70
13	LOCKING PAD	SS201	SS201

TEST SPECIFICATION

TEST ACCORDANCE TO PER API 598
 SHELL TEST: 1500 PSI
 SEAT TEST: 1100 PSI
 AIR TEST: 87 PSI

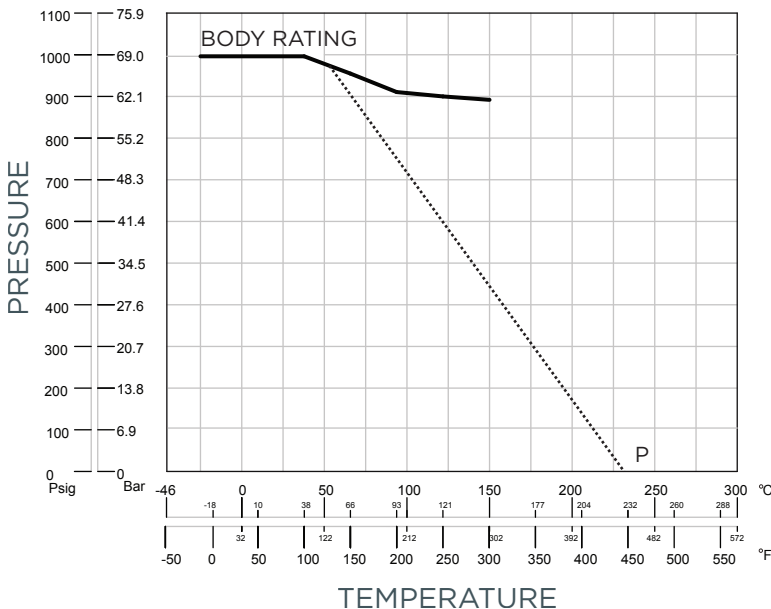

DIMENSIONS & WEIGHT

SIZE	A	B	C	D	WEIGHT (KG)
1/4"	1.57	0.20	1.81	3.07	0.10
3/8"	1.77	0.28	1.26	3.90	0.10
1/2"	2.20	0.35	1.57	4.13	0.15
3/4"	2.36	0.47	1.65	4.69	0.26
1"	2.83	0.59	1.97	6.10	0.44
1 1/4"	3.11	0.75	2.13	6.18	0.67
1 1/2"	3.27	0.94	2.44	6.77	0.81
2"	3.94	1.26	2.76	8.66	1.35

*DIMENSIONS ARE EXPRESSED IN INCHES
 *FOR DIMENSIONS "C&D" THERE IS A TOLERANCE OF ±.24 IN, FOR "A" ±.08 IN